

LDUH15A-A Dosing units for shotcrete liquid admixtures

1. Description:

LDUH15A-A is a compact, safe and reliable liquid dosing unit. It is designed to add additives for dry and wet spraying. It's driven by compressed air, which makes the machine more compact, safe, and reliable in structure.

All components which come into contact with additives are made of high-quality materials. This enables a reliable and durable operation. The pump even withstands a dry run.

Accurate dosing of liquid admixtures becomes very easy with this device.

Connect the water and air hose to the valves, place the suction lance into the additive tank, start the pump and adjust the required dosing with the air valve.

2. Features:

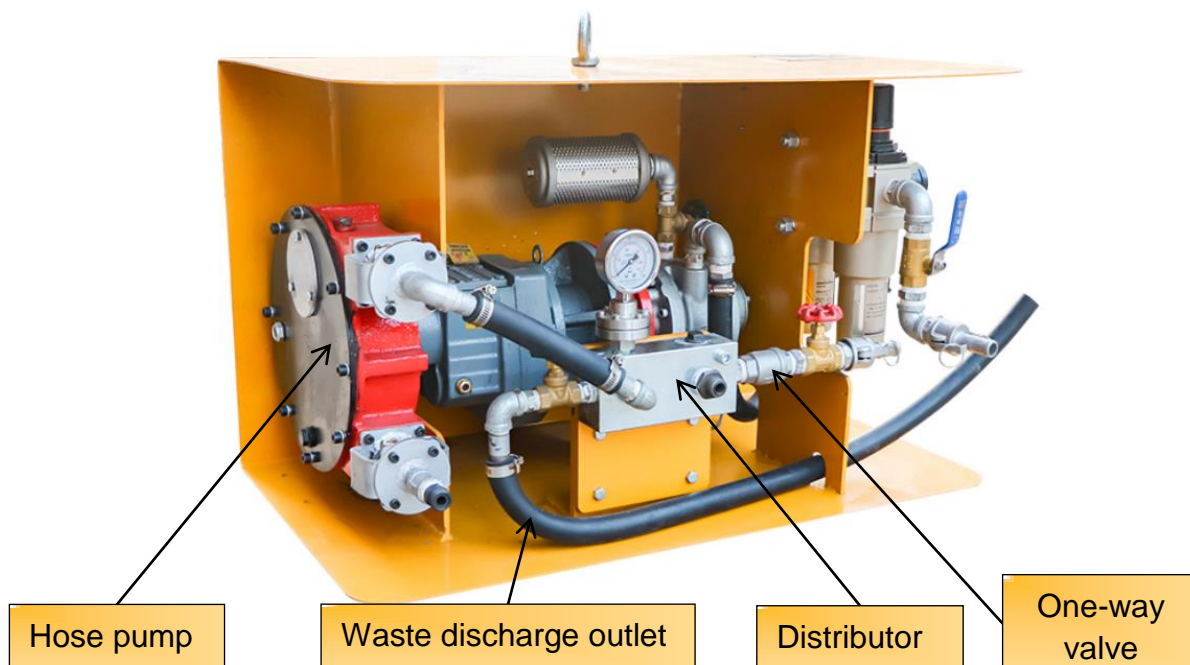

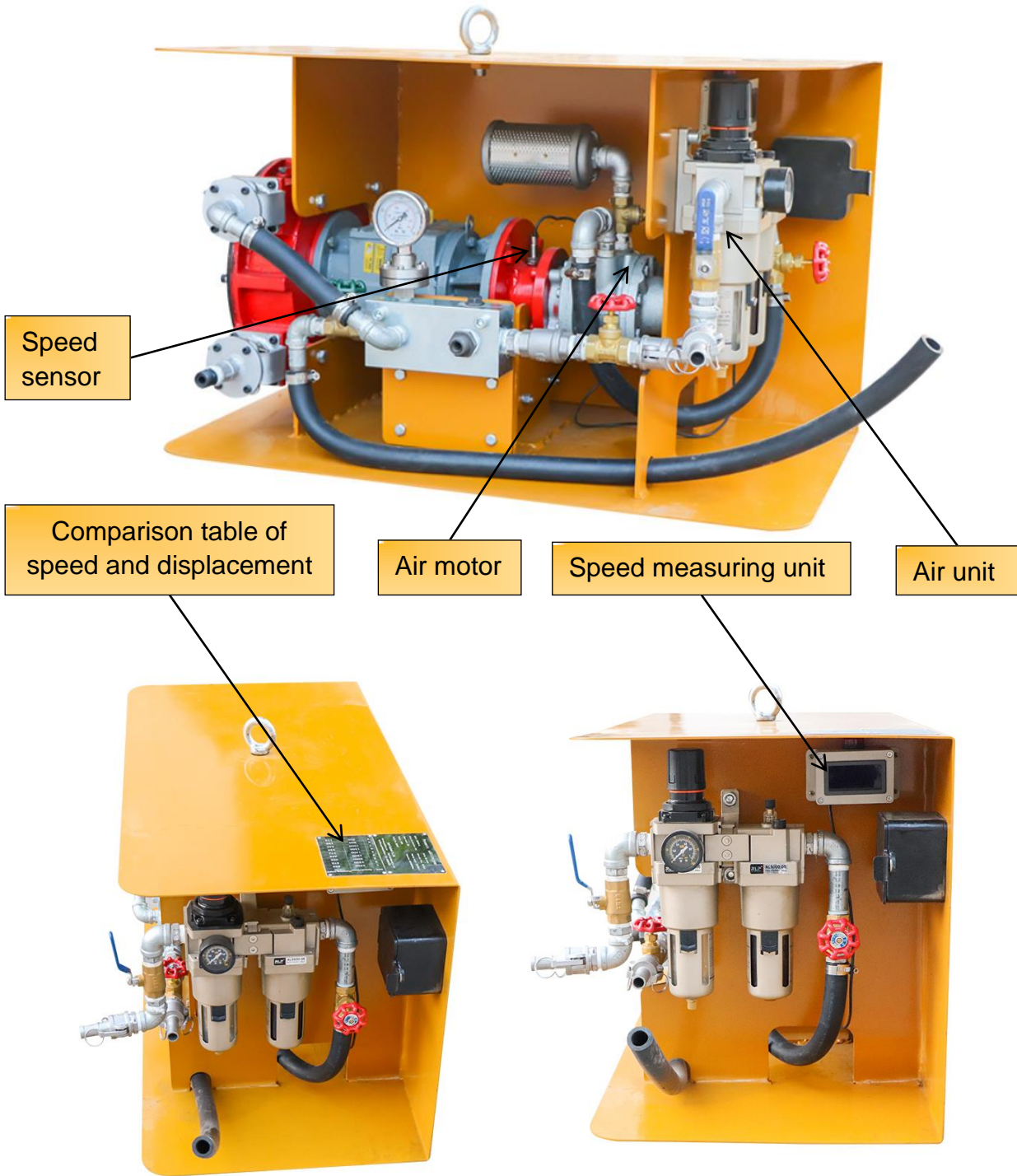

ADVANTAGES AND BENEFITS:

- ◆ Direct drive 4kw air motor;
- ◆ Precise dosing;
- ◆ For dry and wet spraying;
- ◆ Little rebound;
- ◆ Infinite regulation;
- ◆ Dry run resistant;
- ◆ Pressure gauges, pressure visible;
- ◆ One-way valve, for drinking water protection;
- ◆ Easy to operate and maintain;
- ◆ Lightweight and easy to move.

3. Technology Sheet:

Model	LDUH15A-A
Pumping output	100-600 L/h
Air motor power	4 KW
Hose ID	16 mm
Air pressure	7 bar
Air consumption	3 m ³ /min
Air/Water connection	Quick coupler 3/4"
Conveying water pressure	Min. 4 bar Max. 8.5 bar
Dimension	820×497×500 mm
Weight	160 Kg

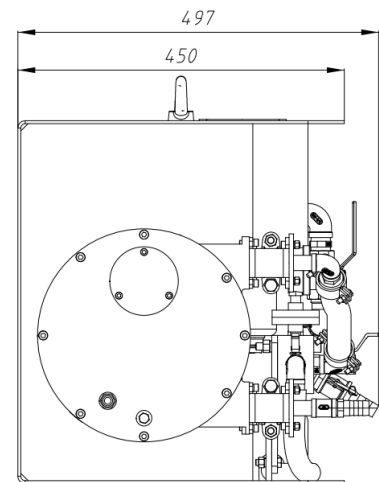
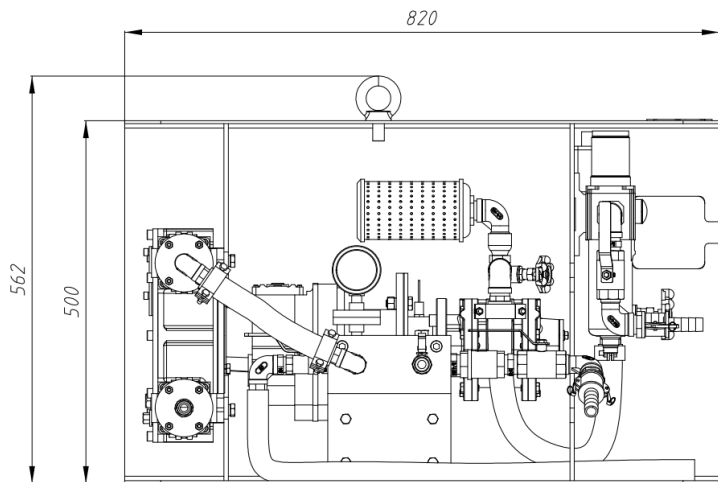

4. Machine Pictures Gallery:



Zhengzhou Lead Equipment Co., Ltd.

Add: Xisihuan Ring-Road East, Tielu, Xiliu lake sub-district, Zhongyuan District, Zhengzhou, Henan

Website: www.leadcrete.net

Email: sales1@leadcrete.com