

LGP400/700/80DPL-E All-in-one grout plant



◆ Product Description:

LGP400/700/80DPL-E All-in-one grout plant is a combination of mixer, agitator and grout pump in one base frame. It is mainly used to be made bentonite slurry, cement slurry, etc., in the application highway, railway, hydropower, construction, mining and other ground and underground construction.

High speed vortex mixer ensures mix quickly and evenly. Water, cement or bentonite is quickly mixed into homogeneous slurry. Then the mixed slurry was delivered to the agitator. Grout pump injects from the mixing drum (storage tank). This ensures a continuous mixing and grouting operations. What's more, the double-cylinder pump together with the pressure-holding system is used, so that the pump automatically stops and maintains the very little pressure impulse (1-4bar with 50bar grouting pressure) to ensure that the grouting hole is completely filled. The grouting plant is hydraulic drive with electric motor. Grouting pressure and displacement is adjustable. Compact size and it is easy to operate. It also takes up a small space.

◆ Product Feature

1. High-speed colloidal grout mixer
2. With the liquid level of the mixer tank
3. Double plunger pump
4. Vertical type pump with compact size
5. Hydraulic drive (safely releasing pressure when pumping block)
6. Hydraulic system with high temperature warning and protection system
7. Pressure holding system
8. Low flow pressure surge system
9. Air cooler and water cooler (suitable for working in tropical and sub-hot areas)
10. Up to 5mm particle size

LGP400/700/80DPL-E Grout/Inject Station

◆ **Model Definition**

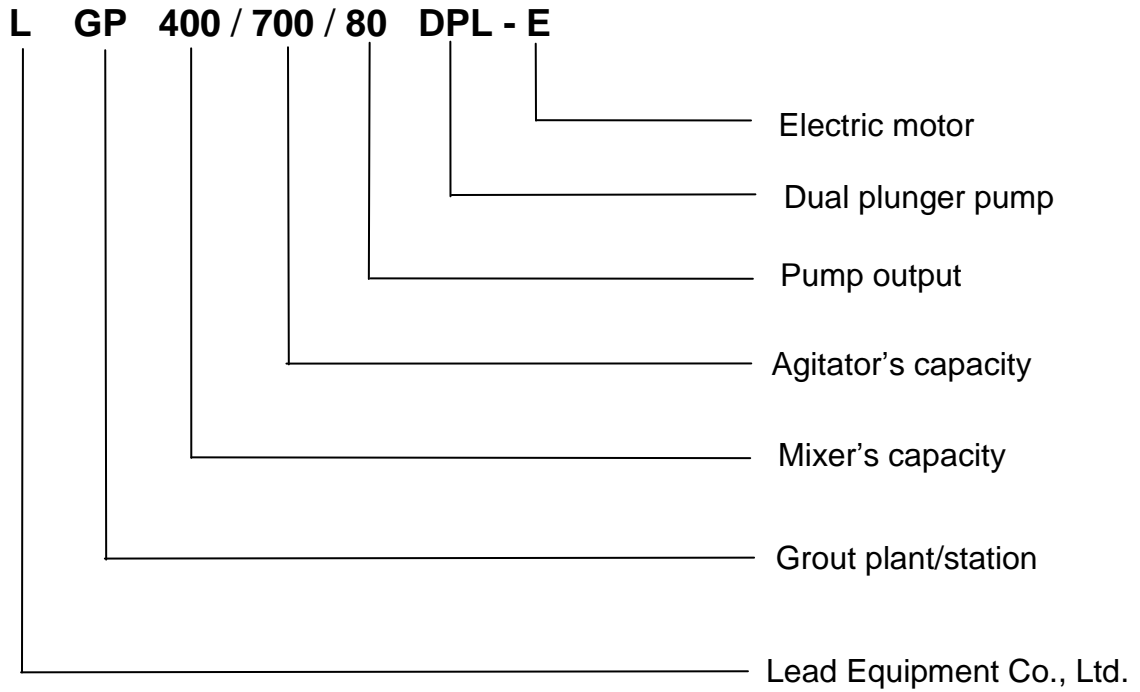

◆ **Product Specification**

Description	Data
Grout Station model	LGP400/700/80DPL-E
Dimensions	2350*2100*1830mm
Weight	1530kg
Mixer	
Capacity	400L
Recycling discharge	1100L/min
Suitable water/cement ratio	≥0.5:1
Motor power	7.5Kw
Rated Rev.	1450rpm
Agitator	
Capacity	700L
Motor model	1.5Kw
Rated Rev.	36rpm
Pump(vertical compact hydraulic grout pump)	
Output/pressure	Low pressure: 0-80L/min, 0-25bar High pressure: 0-58L/min, 0-40bar
Power	11Kw
We could also customize all-in-one grout plant according to your demands.	

LGP400/700/80DPL-E Grout/Inject Station

◆ Detail Part



LGP400/700/80DPL-E Grout/Inject Station



Level Gauge

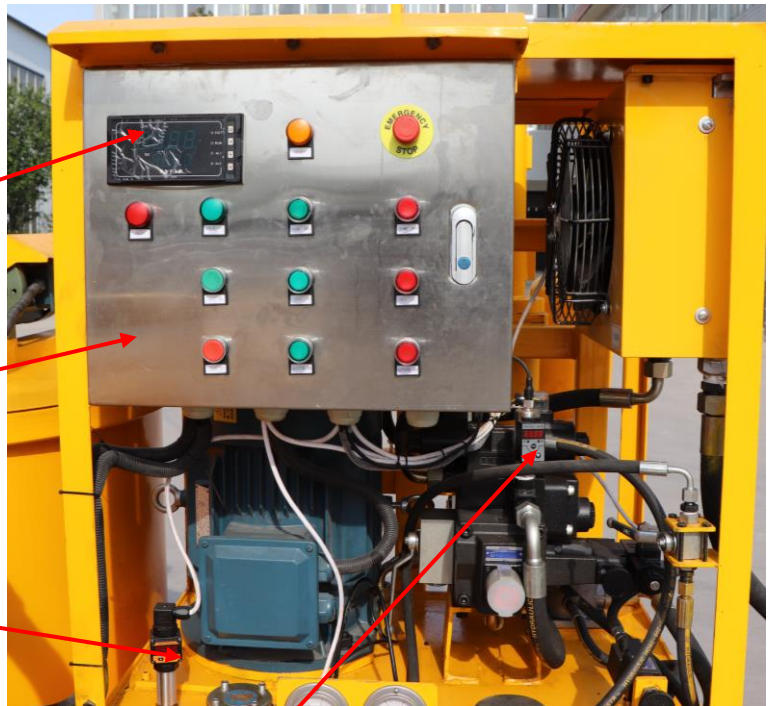

High Temperature Warning and Protection Device

Electric Control Cabinet

Temperature Sensor

Pressure Sensor

LGP400/700/80DPL-E Grout/Inject Station

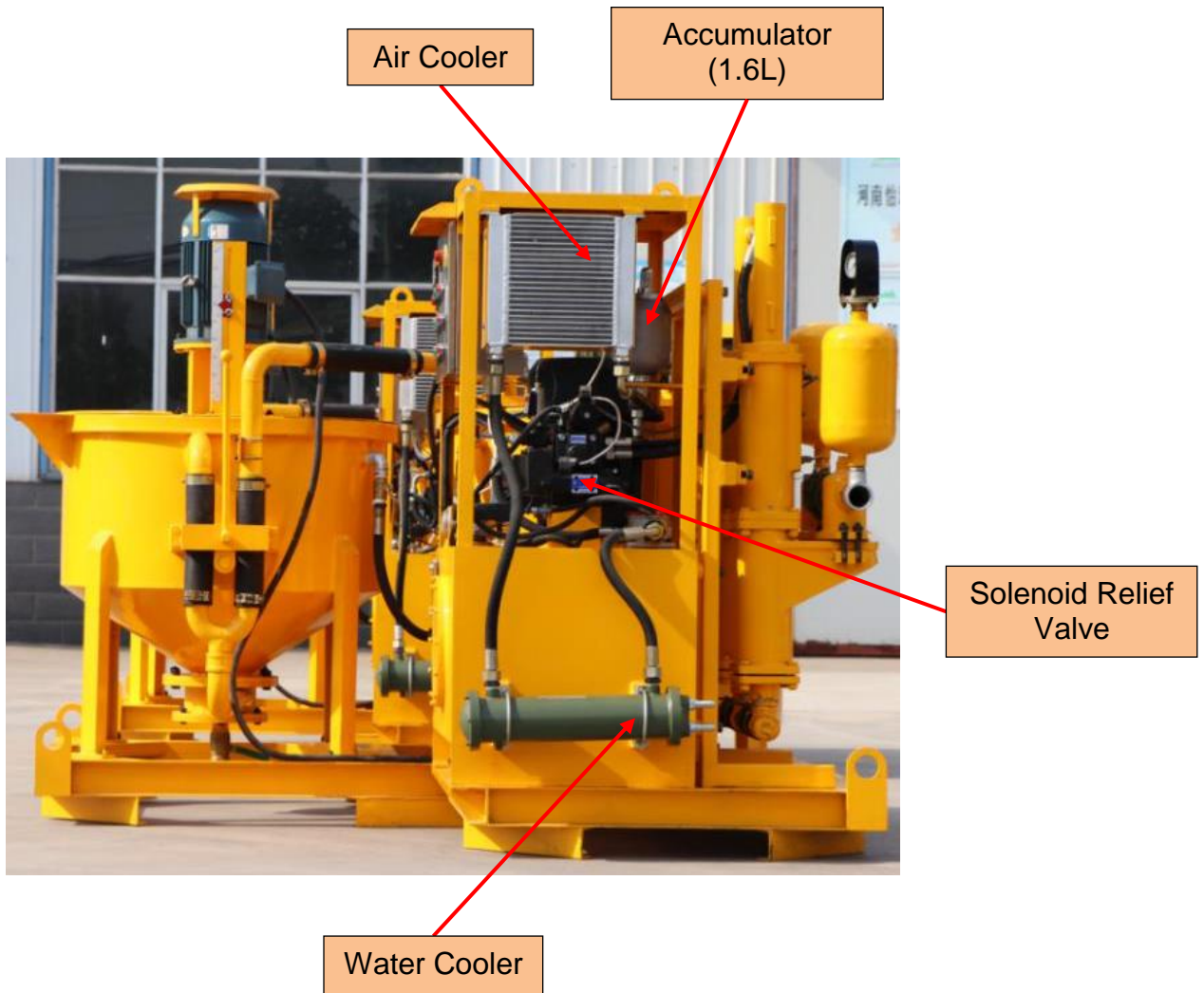

LGP400/700/80DPL-E Grout/Inject Station

◆ Other Angle Pictures



LGP400/700/80DPL-E Grout/Inject Station

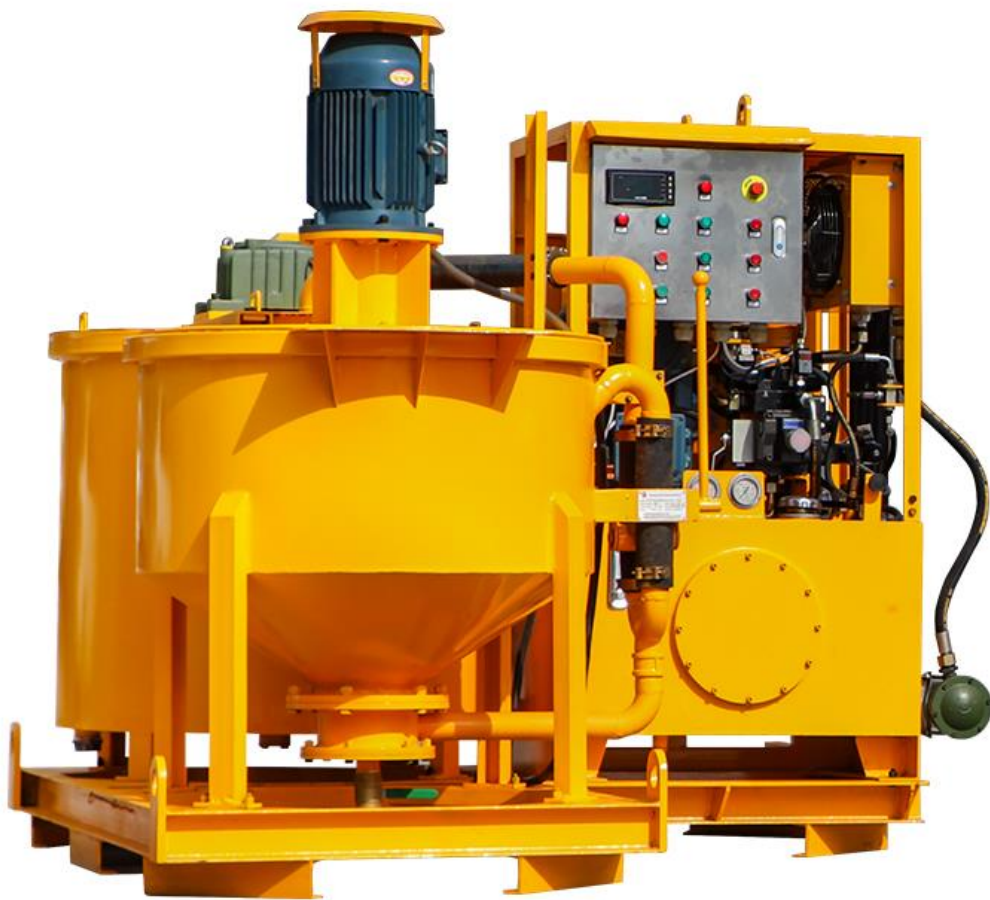

LGP400/700/80DPL-E Grout/Inject Station



Zhengzhou Lead Equipment Co., Ltd.

Add: Xisihuan Ring-Road East, Tielu, Xiliu lake sub-district,

Zhongyuan District, Zhengzhou, Henan

Web: <https://www.leadcrete.net>

E-Mail: sales@leadcrete.com

TEL.: +86-371-63902781, 55019537

FAX: +86-371-63526676